

The Delta Mod-Tech® EDGE Laser Converting System

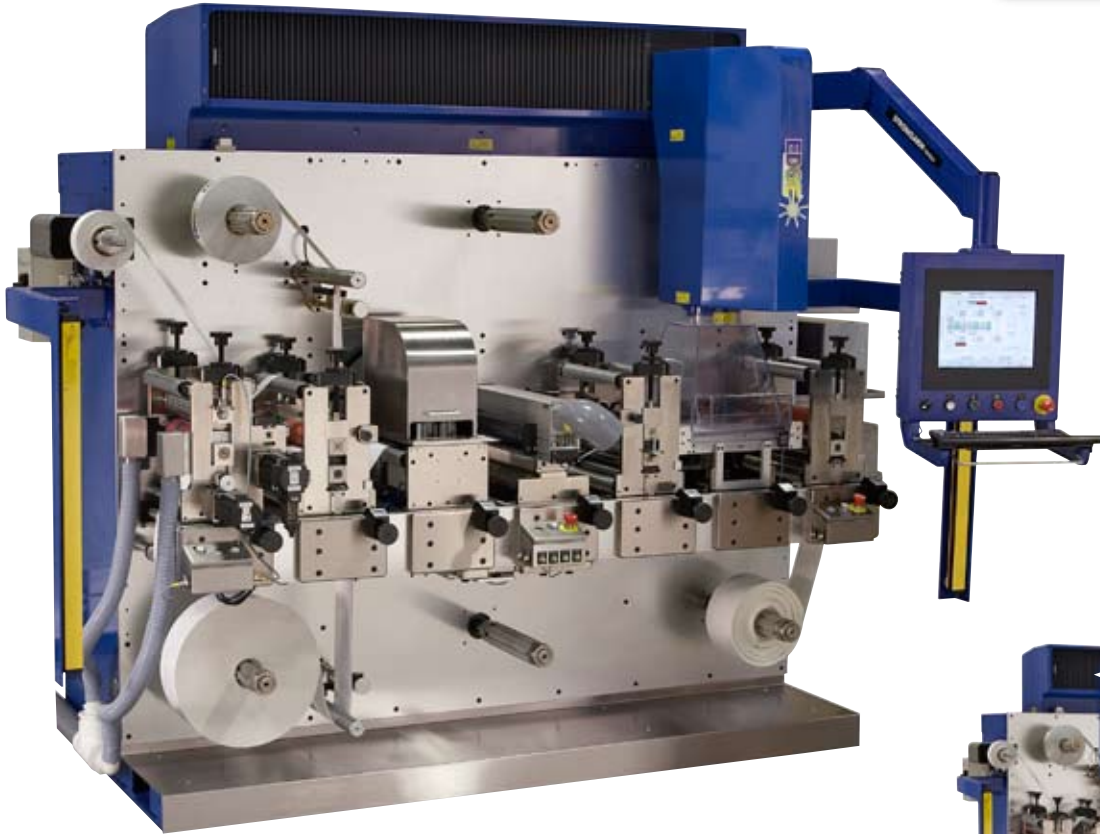

*Digital Laser Cutting -
No Tooling Needed!*

*Specializing in
Solutions for
Complex Geometries,
Precision Products and
Quick-Change.*

This Delta Mod-Tech® manufacturing solution features the standard Edge Laser module as well as optional input web steering, pneumatic rewind, island placement and digital printing modules.

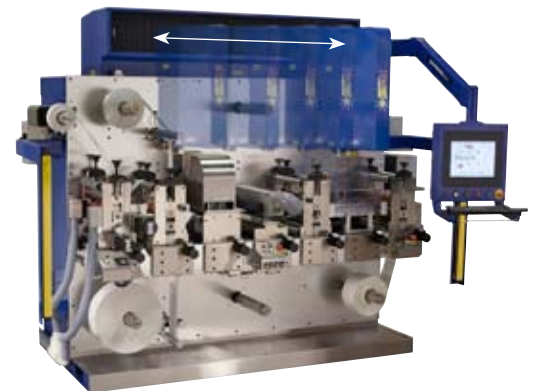

Features:

- No maximum repeat
- No minimum repeat
- Tight Tolerance
- Intricate cuts
- Vary depth of cuts
- Variety of cuts
perforate, kiss-cut, thru-cut
- Intensity: 200, 300 and 400 watt
- C02 Laser
- Field of view 13" x 13"

Benefits:

- Design Flexibility
- Cost Efficient
- High Quality Output
- Unlimited Design Options
- Minimal Material Waste
- High Reliability
- Low Maintenance
- One Machine,
Many Solutions...

Extreme Flexibility - Delta Mod-Tech®'s modular design offers servo controlled laser module repositioning. The laser may be run in the 2nd position for one application, the 4th position for another and the 5th for yet another. The possibilities are endless with Delta... custom engineered solutions for today and flexibility for the future.



**11501 Eagle Street NW
Minneapolis, MN 55448**

1-800-279-3358 • 763-755-7744 • Europe: +46 706-97 24 34 • www.deltamodtech.com

Standard design includes 6 unwind/rewinds.
Options include: tension controls, transducers and dancers.

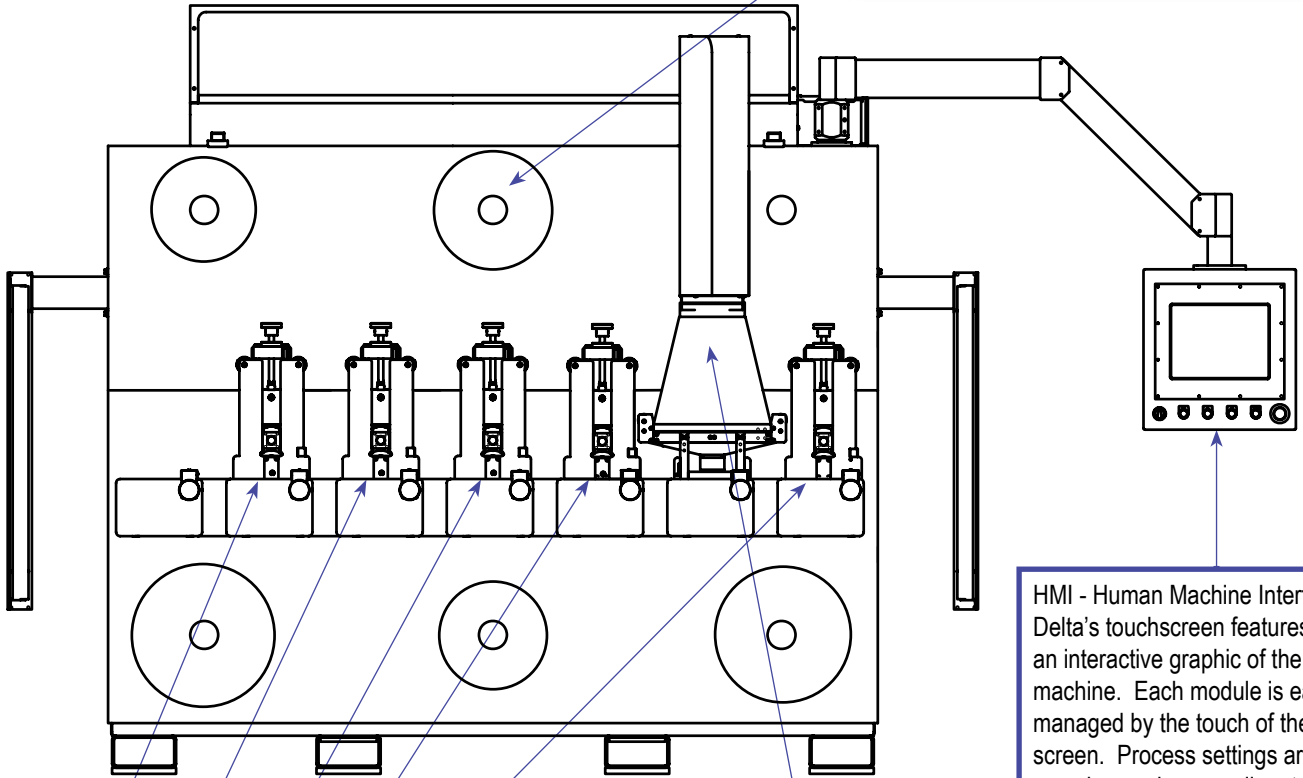

HMI - Human Machine Interface
Delta's touchscreen features an interactive graphic of the machine. Each module is easily managed by the touch of the screen. Process settings are saved as recipes, easily retrieved per application.

Rotary Die Modules: The cornerstone of our converting systems. Each Rotary Die Module can be used for any of the following processes by simply changing the tool roll:

- Laminating
- Nipping
- Die Cutting
- Punching
- Embossing
- Slitting
- Sheeting

Optional Process Modules may be added and removed, as needed, per application specifications.

- Island Placement
- Flexographic Printing
- Digital Printing
- Drying
- Packaging
- Custom Processes



The Edge Laser module offers a flexible solution to your high demand, complex and precise process, die-cutting needs.

- Intensity: 200, 300 and 400 watt units available
 - CO2 laser - efficient, high reliability & low maintenance
 - Flexible - Laser module may be repositioned in production process order.
 - A total solution for quick change in digital printing and labeling
 - Retrofit - expand your current capabilities.
- The Edge laser module may be added to your current Delta equipment.

